

THIS DOCUMENT AND THE INFORMATION IT CONTAINS IS THE PROPERTY OF EMTEQ INC. AND MAY NOT BE USED IN ANY WAY WITHOUT THE EXPRESS WRITTEN CONSENT OF EMTEQ INC.

REV	REVISION	DATE	ER #	INTL
IR	INITIAL RELEASE	03/23/2010	10669	VML

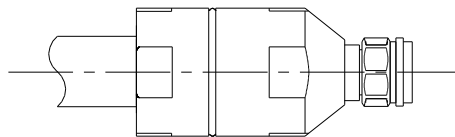
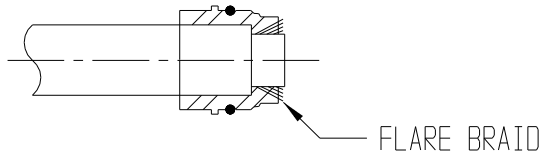
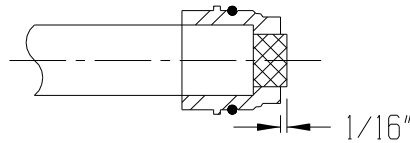
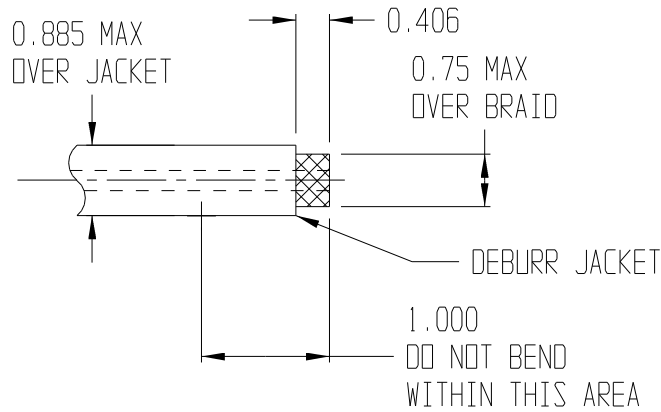

ES-105-66 CABLE ASSEMBLY INSTRUCTIONS

- 1.) TRIM CABLE FLUSH & SQUARE. CABLE NEEDS TO BE CUT IN CIRCULAR MOTION TO KEEP CENTER CONDUCTOR FROM BEING PUSHED OFF CENTER. CABLE MUST NOT BE BENT WITHIN THE FIRST INCH OF THE PREPARED END. DEBURR/CHAMFER THE INSIDE DIAMETER OF THE CENTER CONDUCTOR.
- 2.) REMOVE JACKET TO DIMENSION SHOWN USING THE ST-900/1200C STRIP/PREP TOOL (TIMES MICROWAVE) BY INSERTING THE CABLE INTO THE PROPER END AND ROTATING THE TOOL. BE SURE THERE IS NO JACKET MATERIAL STUCK IN THE TOOL BEFORE BEGINNING THIS OPERATION. DEBURR JACKET TO ALLOW EASY INSERTION INTO CLAMP NUT ASSEMBLY. CLEAN DEBRIS FROM FACE OF CABLE. STRAIGHTEN ANY BRAID THAT MAY HAVE BEEN DISTURBED DURING THE STRIPPING PROCESS. A PROPERLY CUT/TRIMMED CABLE JACKET & BRAID WILL BE WITHIN MAX DIAMETERS SHOWN.
- 3.) INSERT TRIMMED CABLE INTO NUT ASSEMBLY UNTIL JACKET BOTTOMS OUT. KEEPING THE NUT ASSEMBLY ALIGNED WITH THE CABLE & USING A ROTATING MOTION WILL EASE INSERTION OF CABLE INTO NUT ASSEMBLY. THERE SHOULD BE 1/16" OF BRAID PROTRUDING BEYOND THE CLAMP NUT ASSEMBLY WHEN FULLY INSERTED.
- 4.) FLARE BRAID OUTWARD AGAINST TAPER OF CLAMP NUT.
- 5.) INSERT CABLE/NUT ASSEMBLY INTO REAR PORTION OF CONNECTOR BODY. NOTE: CABLE CONDUCTOR WILL PLUG ONTO CONNECTOR CENTER CONTACT. KEEPING THE CABLE PUSHED FORWARD INTO THE CONNECTOR, ENGAGE THREADS & TIGHTEN NUT SECURELY USING 1-1/4" WRENCHES.

DATE 03/23/2010	EMTEQ	5349 S. EMMER DRIVE NEW BERLIN, WI 53151 (888) 679-6170		
DRAWN V. LEX		CABLE STRIPPING INSTRUCTIONS		
DESIGNED	CHECKED <i>[Signature]</i> 03/26/2010			
APPROVED T. FORST	03/26/2010	CAGE CODE 06WH3	DWG #	SHT 1 OF 1

FILE: ES-105-66.prt